



Barcode: 5060452080628

flambank™

Product code: FB2

- » Secure hazardous vault for storing hazardous goods safely.
- » Fully welded sump helps contain any leakages.
- » Ventilation allows airflow and helps prevent the build-up of fumes.



Product features



2x 5-lever
deadlock



Gas strut (300N)



Forklift skids



COSHH
compliant



85L
Sump capacity



Fire resistant



Lid safety stay



Safety signage

Product specifications

Weight	82kg
Colour	Traffic red: RAL 3020
Suitable for	Outdoor storage of flammables or chemicals
Finished coating	Powder coated
Material & thickness	2mm and 3mm steel
Quantity of keys	3 keys
How are castors fitted?	Quick-fix bolt on castor kit
Other sizes available	6 other sizes
Ventilation	Yes
Qty of shelves as standard	Not applicable

Dimensions

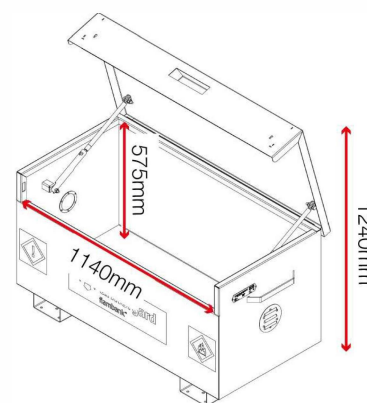
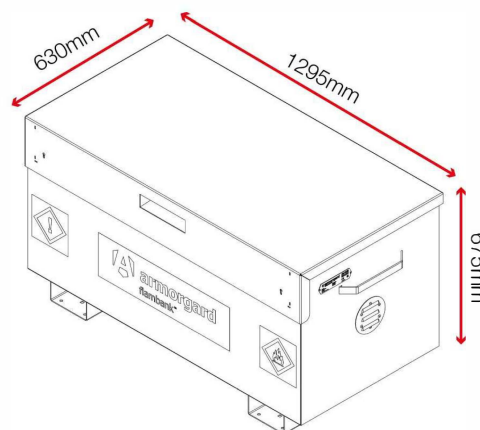

Optional extras



Castor kit CAS160-KS-FX-SB-CP