



Barcode: 5060452080253

fittingstor™

Product code: FC2

- » Secure cabinet designed for storing fittings and materials.
- » Complete with two removable shelves and six individual storage bins.
- » Heavy-duty doors with anti-jemmy protection.



Product features



2x 5-lever
deadlock



Forklift skids



Suitable for site

Product specifications

Weight	89kg
Colour	Black grey: RAL 7021
Suitable for	Site
Finished coating	Powder coated
Material & thickness	1.6mm and 2mm steel
Quantity of keys	3 keys
Suitable for vehicle mounting	No
How are castors fitted?	Quick-fix bolt on castor kit
Other sizes available	4 other sizes
Qty of shelves as standard	2

Dimensions

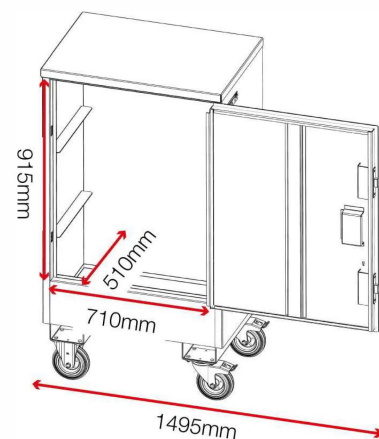
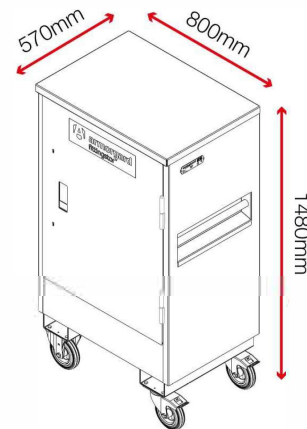

Optional extras



Fittings bins FCB



FittingStor shelf FC-S