

HOLEMAKER TECHNOLOGY
HMT

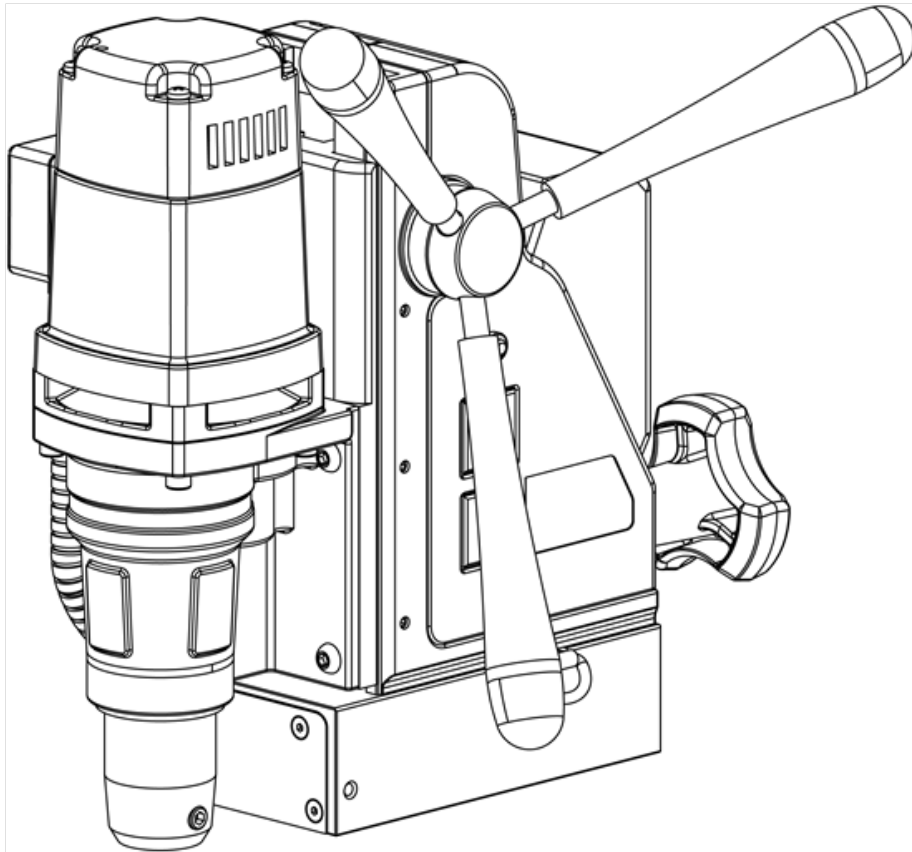

HMT V36-18

Cordless Magnetic drilling machine



Congratulations on purchasing this premium magnetic drilling machine. At HMT we strive to exceed our customers' expectations by developing and providing premium and innovative portable drilling and cutting solutions. We believe that a professional like you must be able to rely on a professional supplier. Which has led us to become a major player in the industrial world, with our own factory and several offices worldwide. All because we have always listened to our customers and to the demands from the market.

Our vision is focused on developing innovative portable tools that add value for our customers and facilitate them in their daily work. We never lose sight of sustainability, time savings and cost savings.

Enjoy your new machine!

Before operating your new magnetic drilling machine, please first read all instructions. You will find the instructions in this manual and on the warning label on your machine. With proper use, care and maintenance your machine will provide you with years of premium drilling performance.

TO REDUCE THE RISK OF INJURY USER MUST READ AND UNDERSTAND ALL INSTRUCTIONS

To view all our offices and their contact information please visit www.holemaker-technology.com

The original manual has been produced in the English language. If any discrepancies should occur in translations, reference must be made to the original version for clarification.

Table of contents

1. Safety	4
1.1 General safety instructions.....	4
1.2 Specific safety information for drilling	6
2. Description	8
2.1 Intended use	8
2.2 Description and features	8
2.3 Case content	9
2.4 Serial number.....	9
2.5 Technical data.....	10
2.6 Symbols.....	11
2.7 Environmental	13
3. Preparation & adjustment	14
3.1 Assembly.....	14
3.2 Prior to use	16
4. Using the machine	17
4.1 Control panel	17
4.2 Permanent magnetic base.....	18
4.3 Switching magnet ON/OFF	19
4.4 Switching motor ON/OFF.....	19
4.5 Tool lubrication.....	20
5. Working with drilling accessories	24
5.1 Annular cutters	24
5.2 Weldon twist drill	25
5.3 Weldon Countersink.....	25
6. Battery pack and charger	26
6.1 Battery pack.....	26
6.2 Battery Charger.....	28
7. Maintenance	30
8. Trouble shooting	32
9. Exploded views & spare parts list	33
9.1 Exploded views	33
9.2 Sparepart lists	32
9.3 Wiring diagram	33
9.4 Warranty and service.....	34

1. Safety

1.1 General safety instructions

Do not use this power tool before you have thoroughly read and completely understood this manual, specifically the “General safety instructions” and “Specific safety information”, including the figures, specifications, safety regulations and the signs indicating DANGER, WARNING and CAUTION.



WARNING: *When using this power tool, basic safety precautions should always be followed to reduce the risk of fire, electrical shock and personal injury.*

Please also observe the relevant national industrial safety regulations. Non-observance of the safety instructions can lead to an electric shock, burns and/or severe injuries.

This manual should be kept for later use and enclosed with the magnetic drilling machine, should it be passed on or sold.

The term “power tool” and “machine” in this user manual refers to your AC-powered (corded) power tool or battery-powered (cordless) power tool.

Work area

1. Keep your work area clean and well lit. Cluttered and dark work areas increase the chance of accidents;
2. Do not operate power tools in explosive atmospheres, such as in the presence of flammable liquids, gases or dust. The power tool may create sparks which could ignite the dust or fumes;
3. Keep bystanders, children and visitors away while operating power tool. Distractions can cause you to lose control.

Electrical safety

1. Power tool plugs must match the outlet. Never modify the plug in any way. Do not use any adapter plugs;
2. Avoid body contact with grounded surfaces such as pipes, radiators, ranges and refrigerators. There is an increased risk of electric shock if your body is grounded;
3. Do not expose power tools to rain or wet conditions. Water entering the power tool will increase the risk of electric shock;
4. Do not abuse the cord. Never use the cord to carry the power tool or pull the plug from an outlet. Keep the cord away from heat, oil, sharp edges or moving parts. Replace damaged cords immediately. Damaged cords increase the risk of electric shock;
5. When operating power tools, use an extension cord suitable for outdoor use, this reduces the risk of electric shock;
6. If operating power tools in a damp location is unavoidable, use a residual current device (RCD), this reduces the risk of electric shock.

Personal safety

1. Stay alert, watch what you are doing and use common sense when using a power tool. Do not use a power tool while tired or under the influence of drugs, alcohol, or medication. A moment of inattention while operating a power tool may result in serious personal injury;
2. Dress properly. Do not wear loose clothing or jewelry. Keep your hair, clothing and gloves away from moving parts. Loose clothes, jewelry, or long hair can be caught in moving parts;
3. Avoid accidental starting. Be sure the switch is off before plugging the power tool in. Carrying a power tool with your finger on the switch or plugging in a power tool that has the switch on increases the chance of accidents;
4. Never place hands, fingers, gloves or clothing near drilling area or rotating tool parts;
5. Remove adjusting keys or switches before turning the power tool on. A wrench or a key that is left attached to a rotating part of the power tool may result in personal injury;
6. Do not overreach. Keep proper footing and balance at all times. Proper footing and balance enables better control of the power tool in unexpected situations;
7. Use safety equipment. Always wear eye protection. Dust mask, non-skid safety shoes, hard hat and hearing protection must be used for optimal safety;
8. Always use supplied safety strap during any work on non-horizontal surfaces. Power tool may release from surface.



WARNING: *Wear ear and eye protection when using this power tool.*

Power tool use and care

1. When using this power tool on non-horizontal surfaces, you must use cutting paste. Do not use oil because the oil can drip into the motor unit and battery pack;
2. While operating this power tool, the cutting tool must be cooled and lubricated with high quality cutting lubricants;
3. Always remove the slug from the cutting tool after operation.



WARNING: *The metal slug can be sharp and very hot!*

4. Use clamps or other practical solutions to secure and support the workpiece to a stable platform. Do not use the power tool when the switch does not turn it on or off. Any power tool that cannot be controlled with the switch is dangerous and must be repaired;
5. Disconnect the plug from the power source or removing the battery pack before making any adjustments, changing accessories or storing the tool. Such preventive safety measures reduce the risk of starting the tool accidentally;
6. Store your power tool out of reach for children and other untrained persons. This power tool are dangerous in the hands of untrained users;
7. Maintain your Power tool with care. Keep cutting tools sharp and clean. Properly maintained tools, with sharp cutting edges are less likely to break and are easier to control;
8. Check for misalignment of moving parts, breakage of parts and any other condition that may affect the operation. If you detect damage have the power tool serviced before use. Many accidents are caused by poorly maintained tools;
9. Only use accessories that are recommended by HMT for your power tool model. Accessories that are suitable for one power tool may become hazardous when used on another one.

Battery use and care

1. Recharge only with the charger specified by the manufacturer. A charger that is suitable for one type of battery pack may create a risk of fire when used with another battery pack.
2. Use power tools only with specifically designated battery packs. Use of any other battery packs may create a risk of injury and fire.
3. When battery pack is not in use, keep it away from other metal objects, like paper clips, coins, keys, nails, screws or other small metal objects, that can make a connection from one terminal to another. Shorting the battery terminals together may cause burns or a fire.
4. Under abusive conditions, liquid may be ejected from the battery; avoid contact. If contact accidentally occurs, flush with water. If liquid contacts eyes, additionally seek medical help. Liquid ejected from the battery may cause irritation or burns.
5. Do not use a battery pack or tool that is damaged or modified. Damaged or modified batteries may exhibit unpredictable behavior resulting in fire, explosion or risk of injury.
6. Do not expose a battery pack or tool to fire or excessive temperature. Exposure to fire or temperature above 130 °C may cause explosion.
7. Follow all charging instructions and do not charge the battery pack or tool outside the temperature range specified in the instructions. Charging improperly or at temperatures outside the specified range may damage the battery and increase the risk of fire.
8. When you transport the battery, familiarize yourself with hazardous goods carriage regulations (UN 3480 and UN 3481).

Service

1. Tool service must be performed only by qualified repair personnel. Service or maintenance performed by unqualified personnel could result in risk of injury;
2. When servicing a tool, use only identical replacement parts. Follow instructions in the maintenance section of this manual. Use of unauthorized parts or failure to follow maintenance instructions may create a risk of electric shock or injury;
3. HMT offers Armature kits containing official HMT spare parts suitable for your magnetic drilling machine.

1.2 Specific safety information for drilling

- Keep your fingers away from the drilling area;
- Avoid touching the slug that is automatically ejected by the pilot pin when the working procedure is finished. Contact with the slug when it is hot, or if it falls, can cause personal injuries;
- Always use the safety guard. Before switching on the power tool, ensure that the guard is closed securely;
- Always use the safety strap.
- This power tool is suitable for use on steel with a thickness starting from 6 mm, with zero air gap between the magnet core surface and the mounting surface. Curvature, coats of paint and surface irregularities will create an air gap. Keep the air gap to a minimum;
- Always place the power tool on a flat surface;
- Do not clamp this power tool on small or irregular shaped objects;
- Always place this power tool on a surface that is clear of shavings, chips, swarf and surface dirt;
- Keep the magnet clean and free of debris and swarf;
- Do not switch on the power tool before checking whether the magnetic base has been tightened firmly to the mounting surface;
- Adjust the power tool so that cutter does not extend into the workpiece before drilling. Do not

perform any design, assembly or construction activities on the workpiece while the power tool is switched on;

- Before switching on the power tool, make sure all accessories have been mounted correctly;
- Do not switch on the power tool until it has been mounted and installed according to all above mentioned instructions;
- Always use the recommended speed for the accessories and material you are working with;
- Do not use the power tool on the same workpiece on which electric welders are working;
- Only use an appropriate cutting lubricant. HMT offers a wide range of well-considered cooling and lubrication products to match your requirements;
- Do not use liquid cutting fluids while drilling vertically or overhead. Dip the cutter in cutting paste or apply an appropriate spray for these applications;
- Do not pour cutting fluid into the reservoir while it is mounted in the bracket. Do not allow cutting fluid to enter the drill motor;
- Before use, ensure movable safety guard operates properly;
- In case of a jammed cutter, turn off the power tool, disconnect it from the power supply and then remove the reason for the jam before turning on the power tool again.

Residual risk

In spite of following the relevant safety regulations and their implementation, certain residual risks cannot be avoided. These are:

- Impairment of hearing;
- Risk of personal injury from flying particles;
- Risk of burns due to accessories becoming hot during operation;
- Risk of personal injury due to prolonged use.

Always try to reduce these risks as much as possible.

2. Description

2.1 Intended use

This cordless magnetic drilling machine is intended for commercial use as a drilling machine for drilling materials with a magnetisable surface using annular cutters in a weather-protected environment using the application tools and accessories recommended by HMT. The cordless magnetic drilling machine can only be used horizontally, vertically, or overhead.

2.2 Description and features

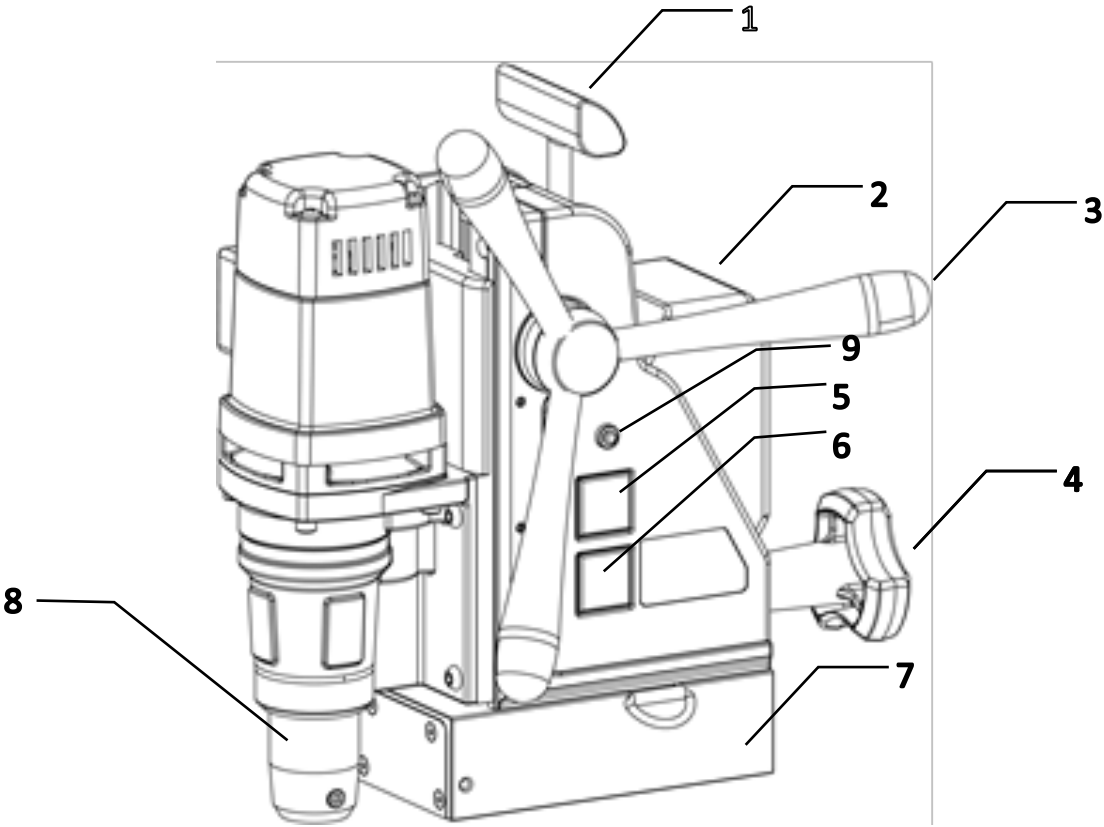

[image 2-1]

- 1. Lifting handle
- 2. Battery pack
- 3. Feed handle
- 4. Magnet switch
- 5. Motor-on switch
- 6. Motor-off switch
- 7. Permanent magnet
- 8. Spindle
- 9. Magnet LED indicator

2.3 Case content (typical example)

- 1 x HMT V36-18 Magnetic drilling machine
- 3 x Feed handles
- 1 x hex key 2.5 mm
- 1 x hex key 3 mm
- 1 x hex key 4 mm
- 1 x hex key 5 mm
- 1 x lubrication system
- 2 x 18v/9Ah battery pack
- 1 x charger for 18v battery pack
- 1 x user manual
- 1 x safety strap

2.4 Serial number

The serial number is mentioned on the machine three times: engraved on the frame, engraved on the magnet and on the serial no. sticker on the motor housing. Additional serial no. stickers are provided with the machine for your administration.

The serial number will help you, your dealer and HMT to validate and identify the machine. For

example:

1002003001

breaks down to:

100 20 03 001

Machine series

Year of manufacture

Month of manufacture

Identification number

2.5 Technical data

Model	HMT V36-18	
Unit	Metric	Imperial
Annular cutting	Ø 12 - 36 mm	Ø 7/16" - 1 7/16"
Weldon twist drill	Ø 1 - 13 mm	Ø 1/16" - 1/2"
Weldon Countersinking	Ø 10 - 40 mm	Ø 3/8" - 1 9/16"
Length	325 mm	12 13/16"
Width	235 mm	9 1/4"
Height	370 -410 mm	14 9/16" – 16 1/8"
Stroke	140 mm	5 1/2"
Weight	9.8 kg	21.6 lbs
Magnet (l x w x h)	157 x 85 x 45 mm	6 3/16" x 3 3/8" x 1 3/4"
Magnetic force	650 kg	1433lbs
Motor power	1,000w	1.33Hp
Speed (no load)	530RPM	
Spindle	19.05 mm Weldon	3/4" Weldon
Rated Voltage	18V	18V
Battery type	lithium-ion	
Battery pack EB5A	18V/5Ah	
Battery pack EB9A	18V/9Ah	
Charge time	EB5A 18V/5Ah/2h EB9A 18V/9Ah/3h	
Power source charger	110-120V AC/60Hz 220-240V AC/50-60Hz	



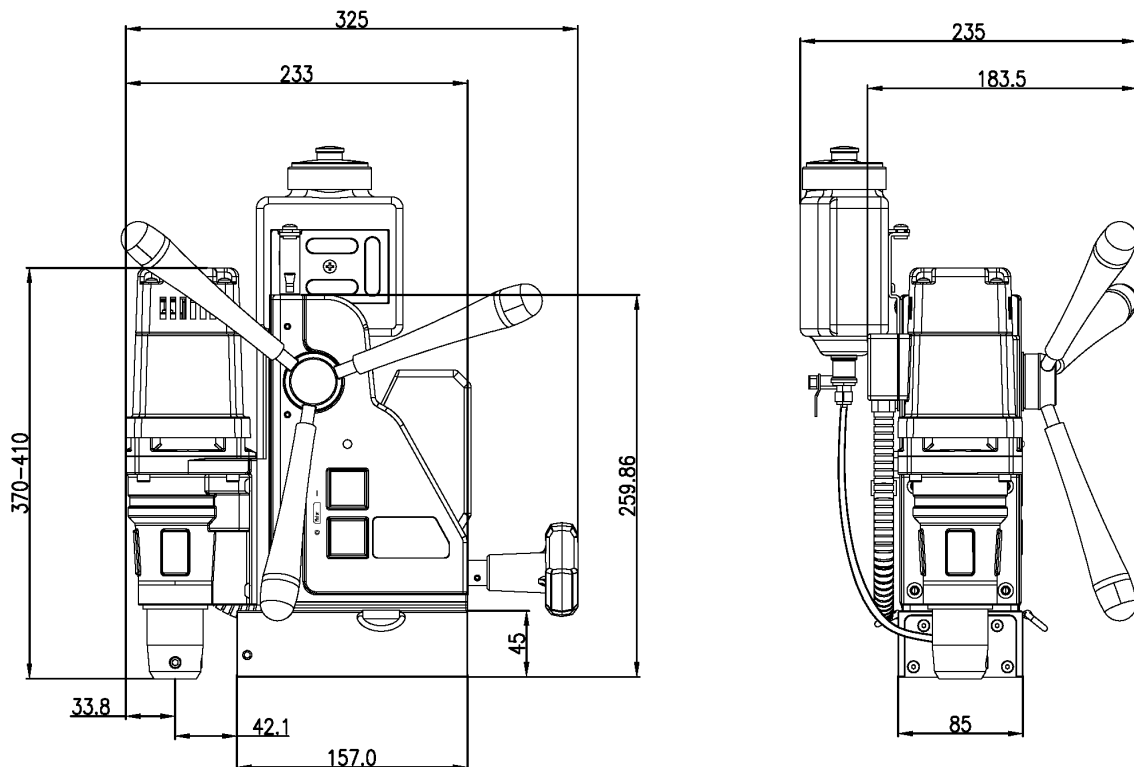

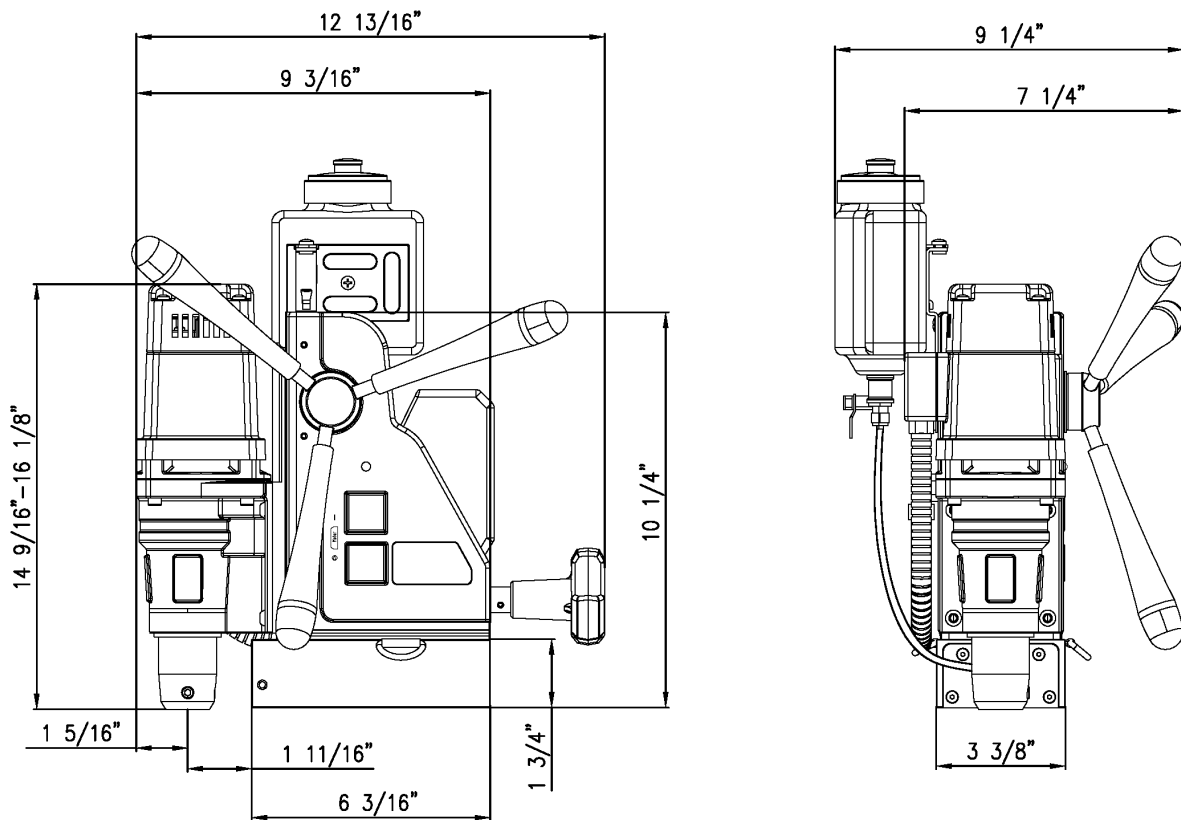

Dimensions (mm)









Dimensions (inches)



2.6 Symbols

Symbol	Term, meaning	Explanation
	Read documentation	Be sure to read the documentation in this user manual and specifically the "General safety instructions" and "Specific safety information"
	Wear ear protection	Use ear protection during operation
	Wear eye protection	Use eye protection during operation
	Indoor use only	To identify electrical equipment designed for indoor use
	Double Insulation	An insulation comprising both basic insulation and supplementary insulation
	Danger/warning/caution	Read and apply the information in the adjacent text!

Symbol	Term, meaning	Explanation
	European conformity	Conformity with EEA machine regulations
	Class of protection I	Product with basic insulation and exposed (touchable) conductive parts additionally connected to the protective earth conductor
	Electromagnetic Compatibility	Able to function acceptably in its electromagnetic environment
	International Electrotechnical Commission	Conformity with international electrotechnical safety standards
	ISO9001	Made in accordance with ISO9001:2015 quality management system
	UL	Certified by Underwriters Laboratories (UL), a recognized laboratory for safety testing approved by US federal agency OSHA
mm	Millimeter	Unit of measure for the dimensions
"	Inch	Unit of measure for the dimensions
kg	Kilogram	Unit of measure for the mass
lbs	Pound	Unit of measure for the mass
V	Volt	Unit of measure for the electric voltage
A	Ampere	Unit of measure for the electric current intensity
W	Watt	Unit of measure for the output
rpm	Revolutions per minute	Unit of measure for the revolutions

2.7 Environmental



Separate collection. This product must not be disposed of with normal household waste.



Separate collection of used products and packaging allows materials to be recycled and used again. Re-use of recycled materials helps prevent environmental pollution and reduces the demand for raw materials.

Local regulations may provide for separate collection of electrical products from the household, at municipal waste sites or at the retailer when you purchase a new product.

3. Preparation & adjustment

3.1 Assembly



WARNING: To reduce the risk of injury, remove the battery pack from the power tool before installing and removing accessories, before adjusting or changing set-ups or when making repairs. Be sure all switches are in the OFF position. An accidental start-up can cause injury.

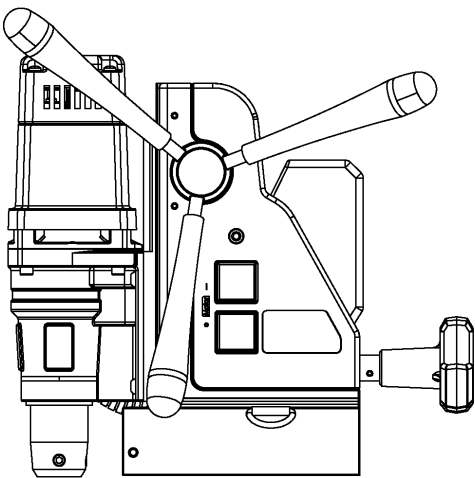

[image 3-1]

Fitting the feed handles

1. Fit each of the three feed handles by screwing them into the hub in clockwise direction;
2. Tighten firmly by hand.

The handles are supposed to face slightly outward. Be careful not to cross-thread any of the components.

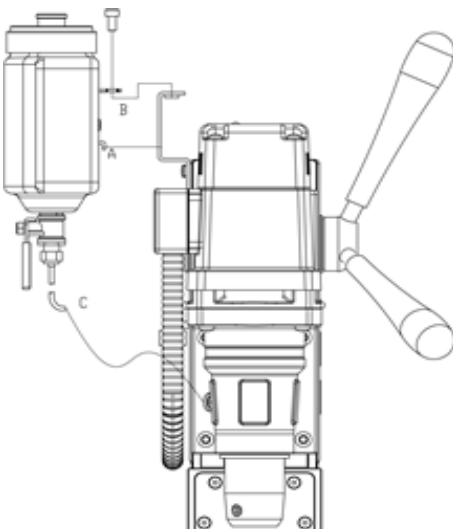

[image 3-2]

Fitting the lubrication system

The lubrication system can only be used for horizontal drilling

1. Hang the tank(A) on the tank holder;
2. Position and tighten the attachment pin(B);
3. Connect the hose(C) to the fitting on the gearbox. Make sure the hose is connected fully and tightly;
4. To disconnect the hose, press the blue ring on the connection and gently pull out the hose.

In order to use the lubrication system, it must be filled with a sufficient amount of cutting fluid.

1. Make sure the flow regulator is closed;
2. Unscrew the cap;
3. Fill the container with cutting fluid;
4. Screw the cap back on.



WARNING: Do not use the lubrication system in inverted drilling applications.

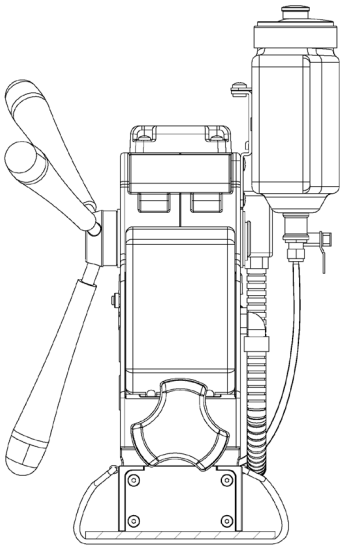

Fitting the safety strap

1. Pass the safety strap through the metal ring on both sides of magnet;
2. Wrap the belt around the workpiece;
3. Securely fasten the machine around the workpiece with safety belt;

[image 3-3]



WARNING: The safety belt does not replace the magnetic force of the magnetic drilling machine: it is simply used to protect the operator in the event of machine slipping

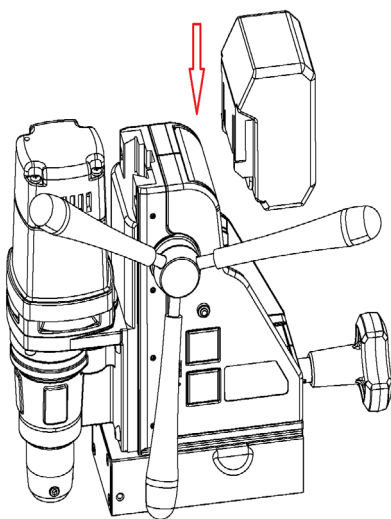

Install & remove the battery pack

1. Battery pack should be installed per illustration, Insert it all the way until it locks in place with a little “click”;
2. To remove the battery pack, press the white unlocking-button on the front of battery and then pull out the battery from its position.

[image 3-4]



CAUTION: Do not install the battery cartridge forcibly. If the battery pack does not slide in easily, it is not being inserted correctly

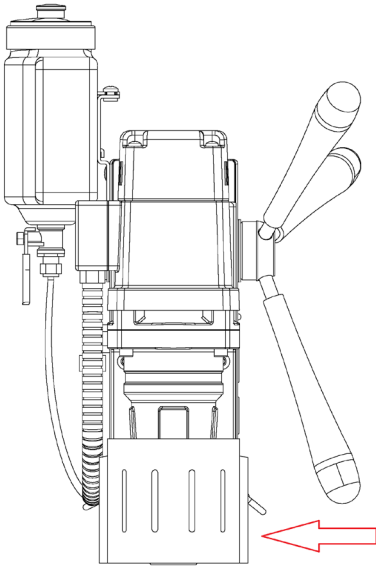

[image 3-5]

Mounting the safety guard

1. The guard protecting against chippings and accidental contact must always be mounted during operation.
2. Hold the guard in front of the magnet, aligning the slots in the guard with the holes in the magnet.
3. Fit the screws into the hole located in the side of the magnet.

WARNING: Always use the Safety guard.

3.2 Prior to use

- ✓ Please make sure that the contacting surface for the permanent magnet base is level, clean and rust free. Remove any varnish or primer. When working on materials that are not magnetisable, suitable fixation devices, obtainable as accessories from HMT, e. g. suction plate, vacuum plate or pipe-drilling machine must be used.
- ✓ When working on steel materials with a material thickness of less than 6 mm, the workpiece must be reinforced with an additional steel plate in order to guarantee the magnetic holding force.
- ✓ Check the machine for possible damage; Before using the machine, you must carefully check the protective components or slightly damaged components to ensure they are operating perfectly and as intended.
- ✓ Check that moving parts are in perfect working order, do not jam and check whether the parts are damaged. All parts must be correctly installed and fulfill all conditions necessary to ensure perfect operation of the machine.
- ✓ Damaged protective components must be repaired or replaced according to specifications by HMT or any authorised HMT dealer.

DO NOT use under wet conditions or in presence of flammable liquids or gases.

DO NOT let children come into contact with the machine. Supervision is required when inexperienced operators use this machine.

Useful tips

- Try a few simple projects using scrap material until you develop a “feel” for the magnetic drilling machine;
- Let the machine run in for a period of eight to ten hours before starting with big operations. Do not load the machine too much during this run-in period;
- Never use the machine with serious overload;
- Keep the machine clear from moisture at all times to protect the machine, yourself and others

4. Using the machine



WARNING: Always observe the safety instructions and applicable regulations.



WARNING: To reduce the risk of serious personal injury, remove the battery pack from the machine before making any adjustments or removing/installing attachments or accessories.

4.1 Control panel

The control panel on your magnetic drilling machine is designed for maximum ease of use and safety.

1. Magnet LED indicator
LED displays green if the generated magnetic force is enough for the tool to operate safely
2. On-switch
This switch is used to switch the motor unit On("I")
3. Off-switch
This switch is used to switch the motor unit On("o")

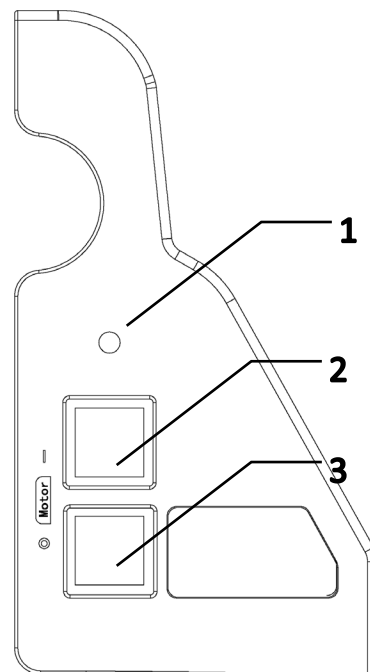

[image 4-1]

4.2 Permanent magnetic base

Make sure the cordless magnetic drilling machine is placed on a smooth, clean, level and solid surface without any objects or debris to guarantee maximum adhesion.

The workpiece must at least be 6 mm (1/4") thick for the magnet to stick and to drill safely. In case the workpiece is between 3 mm (1/8") and 6 mm (1/4"), make sure to make a proper base to create a good magnetic field as shown below.

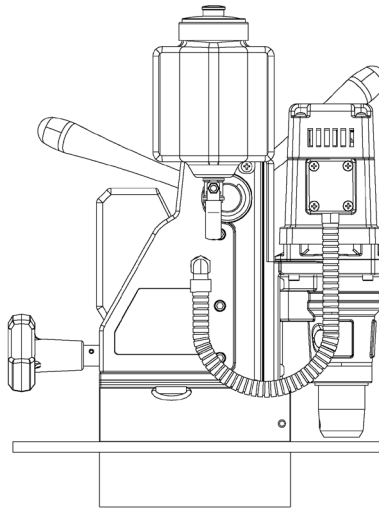

[image 4-1]

When the base is not able to create a good enough magnetic holding force, this may be caused by:

- Surface not being flat;
- Workpiece is not magnetisable (e.g. aluminium);
- Workpiece is coated or painted;
- Workpiece is not thick enough.
- The permanent magnet has been demagnetized

In this situation the magnet LED indicator will not light up green. Make sure to solve any of these matters before proceeding in any way and creating unsafe situations.



WARNING: Do not use this machine when magnet LED indicator is off. Magnet may not generate sufficient holding force.

We want to point out that above mentioned precautions and indicators do not guarantee that the magnet will not release from the material. HMT accepts no liability when it comes to the magnet indicator not functioning or functioning poorly.

Make sure that the magnet attaches tightly to the work piece before turning on the motor unit of the magnetic drilling machine.

4.3 Switching magnet ON/OFF

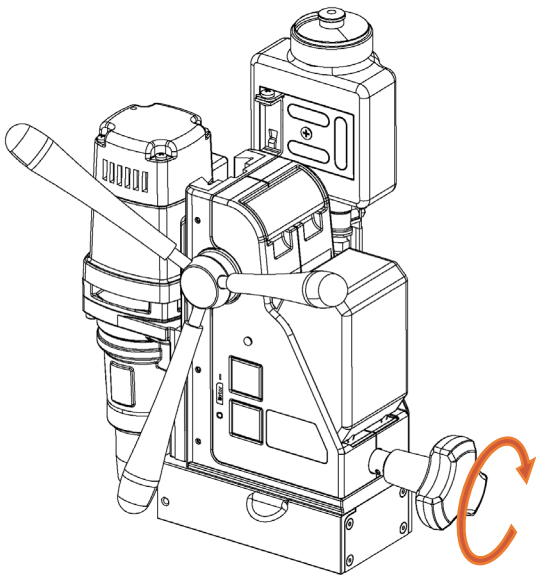

[image 4-2]

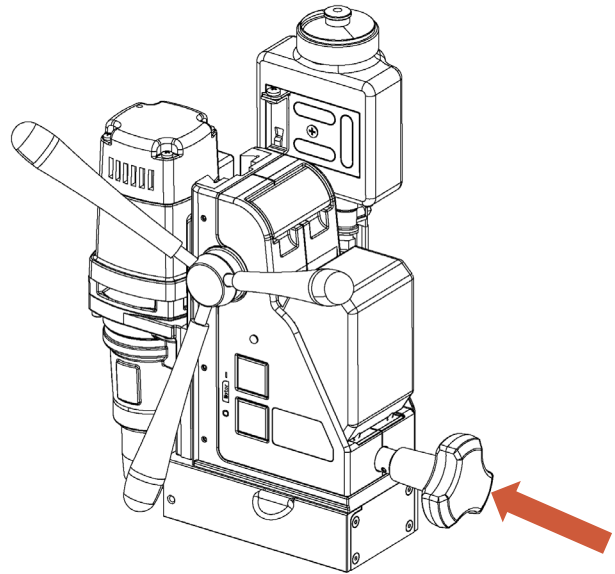

[image 4-3]

- **Activating** the magnetic holding force by rotating the switch knob clockwise ,the magnet LED indicator lights up in green, to indicate that the magnetic holding force is sufficient for drilling.
- **Inactivating** the magnetic holding force by press the switch knob lightly, the magnet LED indicator goes off ,to indicate that the magnetic holding force is off.



WARNING: Do not place the permanent magnet base on hot surfaces ,it could reduce the magnetic holding force and may result in permanent demagnetization of the magnet.

4.4 Switching motor ON/OFF

The motor unit can only be switched ON when the magnet LED indicator is activated. To switch the motor ON, press the green button with marking “I”. To switch the motor OFF, press the red button with marking “O”.

4.5 Tool lubrication

Horizontal applications

In order to use the lubrication system, the tank must be filled with a cutting lubricant.

1. Make sure the flow regulator is closed;
 2. Unscrew the cap;
 3. Fill the container with cutting lubricant;
 4. Screw the cap back on.
- Adjust the fluid flow as required using the flow regulator;
 - Add more cutting lubricant when the shavings (metal chips) become blue.

Vertical and overhead applications

Dip the cutter in cutting paste or apply an appropriate spray



WARNING: Do not use the lubrication system in vertical drilling applications.
Instead use HMT cutting paste or spray.

Make sure to use only suitable cutting lubricants. HMT offers a wide range of cutting lubricants for all tool and material combinations. Proper lubrication will help you create better and faster results, and extend the lifetime of your tools.

5. Working with drilling accessories

5.1 Annular cutters

Annular cutters only cut material at the periphery of the hole, rather than converting the entire hole to shavings. As a result, the energy required to make a hole is lower than for a twist drill.

When drilling with an annular cutter, it is not necessary to drill a pilot hole.



WARNING: Do not touch the cutter or the parts close to the cutter immediately after operation, as they may be extremely hot and cause burns to the skin. Ensure nobody is in the work area where the metal core (slug) is ejected.

Drilling conditions

The ease with which material can be drilled depends on several factors including tensile strength and abrasion resistance. Whilst hardness and/or strength is the usual criterion, wide variations in machinability can exist among material showing similar physical properties.

The drilling conditions are dependent on requirements for tool life and surface finish. These conditions are further restricted by the rigidity of the tool and the workpiece, lubrication and machine power available. The harder the material, the lower the cutting speed.

Some materials of low hardness contain abrasive substances leading to rapid cutting edge wear at high speeds. Feed rates are governed by rigidity of set-up, volume of material to be removed, surface finish and available machine power.

Drilling a hole

Now that you have read the information and safety recommendations above, you are ready to actually start drilling. Follow these 13 steps for best drilling result:

1. Install the annular cutter:
 - Place the pilot pin into the cutter;
 - Align the flat faces on the cutter shank with the screws in the tool holder;
 - Make sure the cutter shank is entered fully and correctly;
 - Tighten the screws;

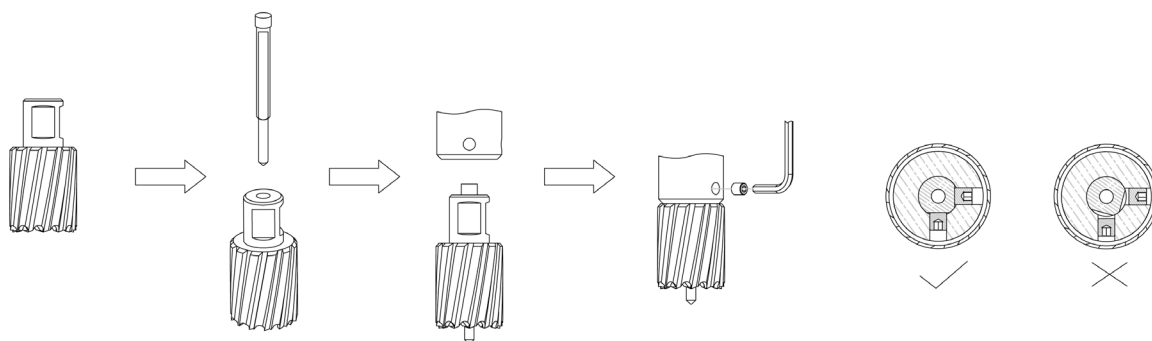

[image 5-1]

2. Loosen the stop screw before turning the feed handles.
3. Precisely mark the center of the hole;
4. Use the pilot pin to position the machine in the correct position, with the tip of the pilot pin to meet the marked center of the hole;

5. Switch on the magnet and verify that the drill is in the right position and that the machine is pushed tight against the work piece;
6. Apply suitable lubrication method;
7. Switch the motor on and allow it to run at the required speed;
8. Turn the feed handles to start drilling. Apply only a slight pressure when the annular cutter touches the metal. Do not push the annular cutter with force into the metal;
9. Apply a regular pressure while drilling. The drilling performance does not improve by putting more pressure on the machine. Too much pressure will overload the motor and your annular cutter will be worn sooner;

A continuous, non-discoloured iron swarf is a sign of correct drilling speed and a well-cooled, sharp cutter. Let the cutter do the job and give it time to cut the metal!

10. Stop drilling regularly, apply suitable lubrication, and continue drilling;
11. Apply less pressure when the drill cuts through the material. The slug will be pushed out of the cutter by the pilot pin;
12. Turn the feed handles to put the motor in highest position and switch off the motor unit;
13. Remove the burrs, metal chips and clean the cutter and surface without getting injuries.



WARNING: *The slug is sharp and may be hot!*

5.2 Weldon twist drill

1. Fit a Weldon shank twist drill (such as HMT 201070 Series) directly to the machine

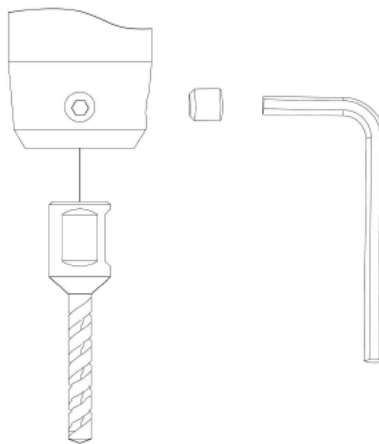

[image 5-2]

2. Precisely mark the center of the hole, and use the tip of the twist drill to position the machine and in the correct position, with the tip of the twist drill to meet the marked center of the hole.

Steps 3-12 ,see chapter Annular cutter

5.3 Weldon Countersink

6. Battery pack and charger

6.1 Battery pack

Read all instructions. Failure to follow all instructions listed below may result in, fire and/or injury.

- Remove the battery pack from the machine before any adjustments, conversions or servicing are performed.
- Before fitting the battery pack, make sure that the machine is switched off.
- Do not open the battery packs
- Do not place the battery pack or cells on or near fires, heaters, other high temperature locations, or apply heat to the battery.
- Do not pierce the battery with any sharp objects, strike the battery with a hammer, tools, or heavy objects, step on the battery pack, or otherwise damage the outer casing.
- Do not subject the battery pack to strong impacts or shocks.
- Do not expose the battery to water or any other type of liquid, or allow the battery to get wet.
- Do not leave the battery in direct sunlight, and avoid storing spare battery packs inside cars in extreme hot weather. Doing so may cause the battery to generate heat, rupture, or ignite. Using the battery in this manner may also result in a loss of performance and a shortened life expectancy. When a battery becomes too hot, the built-in protection circuitry is activated, preventing the battery from charging further. Heating the battery can destroy the safety devices, and can cause additional heating, rupture or ignition of the battery cells.
- Never short-circuit, reverse polarity, disassemble, damage or heat the battery pack over 100°C (212°F).
- If an exposed lithium-ion battery does start a fire, it may burn even more violently if it comes into contact with water or even the moisture in the air. **DO NOT THROW WATER ON A BURNING LI-ION BATTERY!** A class C fire extinguisher must be used.
- Do not use the Battery Pack if the Battery Pack casing is broken or if a Battery Pack emits an unusual odor, smoke, or excessive heat or leaks any substance. Avoid contact with any substance seeping from the Battery Pack.
- The cells within the Battery Packs contain toxic substances. Do not attempt to open Battery Packs. Do not insert any object into the Battery Packs or use any device to pry at the Battery Pack casing. If you insert an object into any of the Battery Packs' ports or openings you could suffer electric shock, injury, burns, or cause a fire. Attempting to open the Battery Pack casing will damage the casing and could release toxic and harmful substances, and will render the pack unusable.
- If battery fluid leaks out and comes into contact with your skin, rinse immediately with plenty of water. If battery fluid leaks out and comes into contact with your eyes, wash them with clean water and seek medical attention immediately
- As with all rechargeable batteries, do not charge near flammable materials.
- Do not disassemble or modify the battery pack. The battery contains safety and protection devices which, if damaged, may cause the battery to generate heat, rupture or ignition.
- Any modification may damage the battery pack or cells and will invalidate any warranty claim.
- If you happen to get any electrolyte from the cells on your skin, wash thoroughly with soap and water. If in your eyes, do not rub. Rinse thoroughly with water and seek medical
- **Obey your local regulations relating to disposal of battery**

BATTERY PROTECTION FEATURES

HMT36-18 18V lithium-ion batteries are designed with features that protect the lithium-ion cells and maximize battery life. Under some operating conditions, these built-in features may cause the battery and the tool it is powering to act differently from nickel-cadmium batteries.

During some applications, the battery electronics may signal the battery to shut down, and cause the tool to stop running. To reset the battery and tool, press off-switch first, and then press on-switch to restart the machine. If fail to reset the battery and tool by applying above steps, the battery pack is depleted.

NOTE: To prevent further shut down of the battery, avoid forcing the tool.

BATTERY CAPACITY INDICATOR

By pressing the check button on the battery pack, the user can check the remaining battery capacity by observing the indicator light.

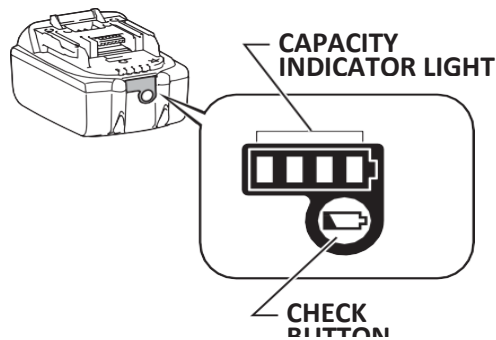

[image 6-1]

Depending on the status of indicator light, the remaining capacity of battery can be read easily by the user:

STATUS OF INDICATOR LIGHT	REMAINING CAPACITY
■ ■ ■ ■	75%-100%
■ ■ ■	50%-75%
■ ■	25%-50%
■	0-25%

[image 6-2]

Note: Depending on the ambient temperature, the indication may differ slightly from the real battery capacity.

6.2 Battery Charger

Read the instructions listed below, Failure to follow them may result in fire and/or injury.

- Protect the battery charger from rain and moisture. Water penetration in a battery charger increases the risk of electric shock
- Do not charge other batteries. The battery charger is suitable only for charging matched lithium-ion batteries within the listed voltage range, otherwise there is danger fire and explosion.
- Keep the battery charger clean. Contamination may increase the risk of electric shock
- Before using, always check the charger, cable and plug. If defects are detected, do not use the charger; never open the charger.
- Have it opened and repaired only by qualified personnel who will use original spare parts. Damaged chargers, cables and plugs increase the risk of electric shock.
- Do not operate the charger on easily inflammable surface (e.g. paper, textiles, etc.) or combustible surroundings. The heating of the charger during charging may cause a fire.
- Plug the charger within the listed voltage range on the charger.
- Unplug the charger from the electrical outlet before attempting any maintenance or cleaning.
- Disconnect charger from the power supply when not in use. This will reduce the risk of electric shock or damage to the charger.
- Do not touch the un-insulated portion of output connector or un-insulated battery terminal.
- This appliance is not intended for use by person (including children) with reduced physical, sensory or mental capabilities, or lack of experience and knowledge, unless they have been given supervision or instruction.
- Children should be supervised to ensure that they do not play with the appliance.
- In the event of any power cord damage, do not change it yourself, return it to HMT dealer or ask a qualified person for help.



WARNING: Do not charge non-rechargeable batteries.

Battery charging



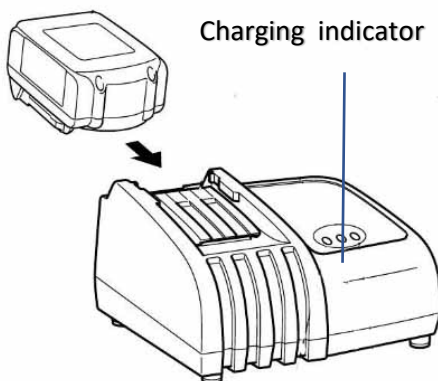



Note: This battery charger is for charging HMT-battery pack. Never use it for other purposes or for other manufacturer's batteries.



1. Plug the charger into the proper AC source, the green charging indicator will light up and blink repeatedly.
2. Insert the battery pack into the charger until you hear a slight "click", the music comes out and the red charging indicator lights up, to indicate that the battery pack has been correctly fitted.
3. With finish of charge, the charging indicator will change from red one to green one and the music comes out again, to indicate that the battery pack has been fully charged.
4. After fully-charge, press the battery release button and then remove the battery pack from the charger and unplug the charger.

Battery Charging indicator

The following sheet shows the charged status of battery

Symbol on charger	Status	Meaning
	GREEN BLINKING	Plug in
	RED ON	Charged condition 0-80%
	RED, GREEN ON	Charged condition 80%-100%
	GREEN ON	Fully charged
	Not available	
	RED, GREEN BLINKING	Defective battery or charger

Note: The battery is equipped with an NTC temperature control which allows charging to be only available within a temperature range of 5°C(41F)-40°C(104F). A long battery service life will be achieved in this manner.

7. Maintenance

Your HMT magnetic drilling machine has been designed to operate over a long period of time. Continuous satisfactory operation depends upon proper tool care and regular cleaning.



CAUTION: To reduce the risk of injury, turn the machine off and remove the battery pack from the machine before installing and removing accessories, before adjusting or changing set-ups or when making repairs. Be sure the switch is in the OFF position. An accidental start-up can cause injury.

Just as every magnetic drilling machine with moving parts, your HMT magnetic drilling machine also needs regular maintenance service. A few recommendations follow :

Visually check the machine for damage

The machine must be checked before operating for any signs of damage that will affect the operation of the machine. If the machine appears to be damaged it should not be used. Failure to do so may cause injury.

Cleaning

- Clean all dirt, dust, metal chips and burrs of your magnetic drilling machine;
- Blow dirt and dust out of the main housing with dry air as often as dirt is seen collecting in and around the air vents. Wear approved eye protection and an approved dust mask;
- Never use solvents or other harsh chemicals for cleaning the non-metallic parts of the tool. These chemicals may weaken the materials used in these parts. Use a cloth dampened only with water and mild soap. Never let any liquid get inside the tool; never immerse any part of the tool into a liquid.

Operation of the machine

The machine's operation must be checked to ensure that all components are working correctly. Replace any defective parts immediately. This prevents properly functioning parts from being damaged.

Check permanent magnetic base

Before every operation the magnetic base should be checked to make sure that the base is flat and there is no damage present. An uneven magnet base will cause the magnet to hold not as efficiently and may cause injury to the operator. When the machine is put out of use for a long period, apply a small amount of machine oil to the underside of the magnetic base for rust protection. Clean the magnetic base again with next use

Adjustment of slide

An essential requirement of the machine is that the slide can move in a smooth and controlled manner, free of lateral movement and vibration.

This situation can be maintained by periodic adjustment of the slide and can be accomplished in the following manner:

1. Place the machine in an upright position and, by means of the capstan, raise the slide to its highest position. Clean the aluminum rails and apply a small amount of light machine oil to the wear surfaces;
2. Gently feed in setting screw with supplied Allen key 2.5 until slight resistance is encountered. Follow your way down adjusting all setting nuts and screws;

3. Operate the slide up and down a few times to test the movement and make any further necessary adjustments. Try to ensure that all the screws are exerting a uniform pressure on the slide from top to bottom. A perfectly adjusted slide will operate freely up and down without any sideways movement.

Lubricating the feed travel

The feed travel should be lubricated periodically with grease to ensure smooth operation.

- Raise the motor unit to the highest position possible;
- Lubricate the dove-tail guideway at both sides;
- Lubricate the gear rack.

After repeated use, the gear rack may become loose. If necessary, adjust the four self-locking set screws at the left side. Tighten screws in series until the gear rack moves freely in the dove-tail guideway but does not allow the motor to wobble.

Repair, modification and inspection

Repair, modification and inspection of HMT magnetic drilling machines must be done by HMT or an HMT authorised dealer. The spare parts list will be helpful if presented with the machine to the HMT dealer for service when requesting repair or other maintenance.

HMT machines are constantly being improved and modified to incorporate the latest technological advancements. Accordingly, some parts (i.e. part numbers and/or design) may be changed without prior notice. Also, due to HMT's continuing program of research and development, the specifications of machines are subject to change without prior notice.

WARNING: *Since accessories, other than those offered by HMT, have not been tested with this machine, use of such accessories with this tool could be hazardous. To reduce the risk of injury, only HMT recommended accessories should be used with this machine.*



Consult your dealer for further information on the appropriate accessories.

8. Trouble shooting

Permanent magnet does function, the motor does not work	<ul style="list-style-type: none"> - Damaged or defective wiring - Defective battery pack - Defective On / Off switch - Defective control unit - Defective armature and/or field
Annular cutters break quickly, holes are bigger than the annular cutter	<ul style="list-style-type: none"> - Clearance in the guide - Bent spindle - Shaft extending from the motor is bent - Bent pilot pin
Motor running roughly and/or seizing up	<ul style="list-style-type: none"> - Bent spindle - Shaft extending from the motor is bent - Triangular guide not mounted straight - Dirt between spindle and triangular guide
Motor starts running when magnetic force is activated	<ul style="list-style-type: none"> - Damage in control unit
Motor making a rattling sound	<ul style="list-style-type: none"> - Gear ring (bottom of the armature) worn out - Gear(s) worn out - No oil in gearbox
Motor does not start or fails	<ul style="list-style-type: none"> - Damaged or defective wiring - Dirt in sensor control unit - Defective or loose magnet on top of armature - Damaged or defective (sensor) control unit - Damage to armature or field coil
Guiding takes a great deal of effort	<ul style="list-style-type: none"> - Guide is set too tight - Guide is dry, needs to be greased - Guide/gear- rack/rotation system dirty or damaged
Insufficient magnetic force	<ul style="list-style-type: none"> - Defective permanent magnetic base
Rotation system free stroke too long	<ul style="list-style-type: none"> - Loose or defective gear rack - Defective rotation system
Blinking light in top display	<ul style="list-style-type: none"> - Machine is in overload protection - Battery is in overheat protection

9. Exploded views & spare parts list

9.1 Exploded views

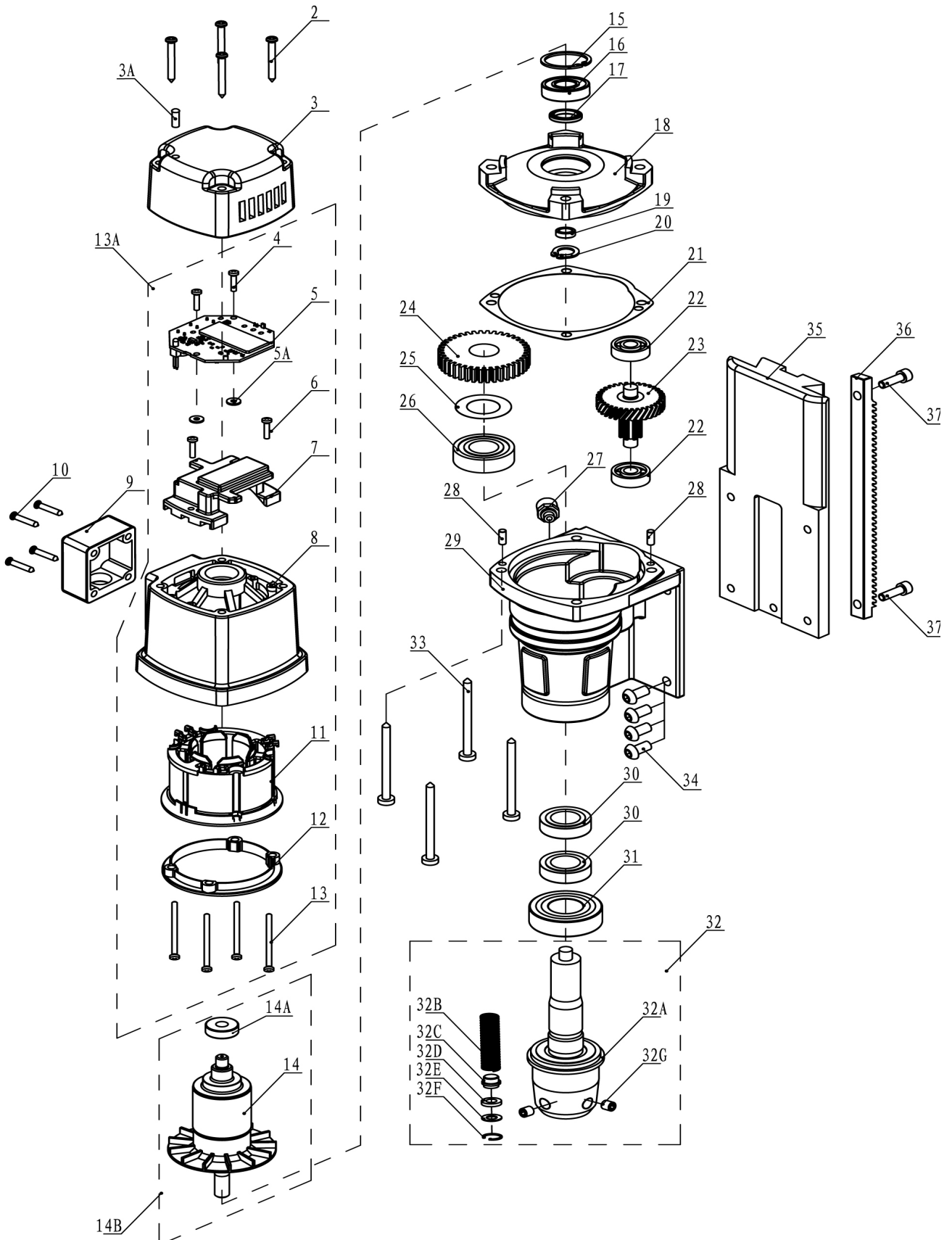

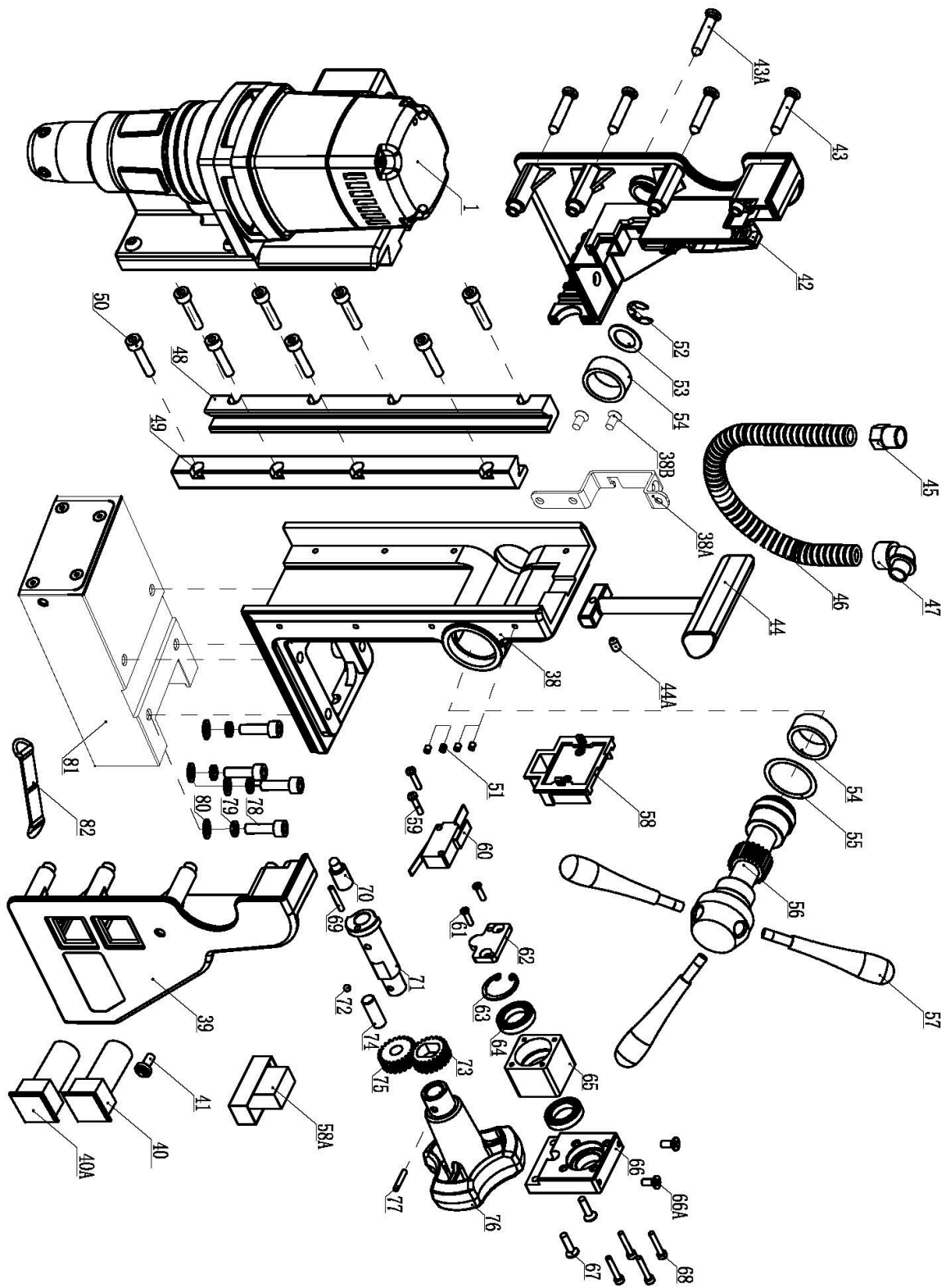

9.3 Wiring diagram

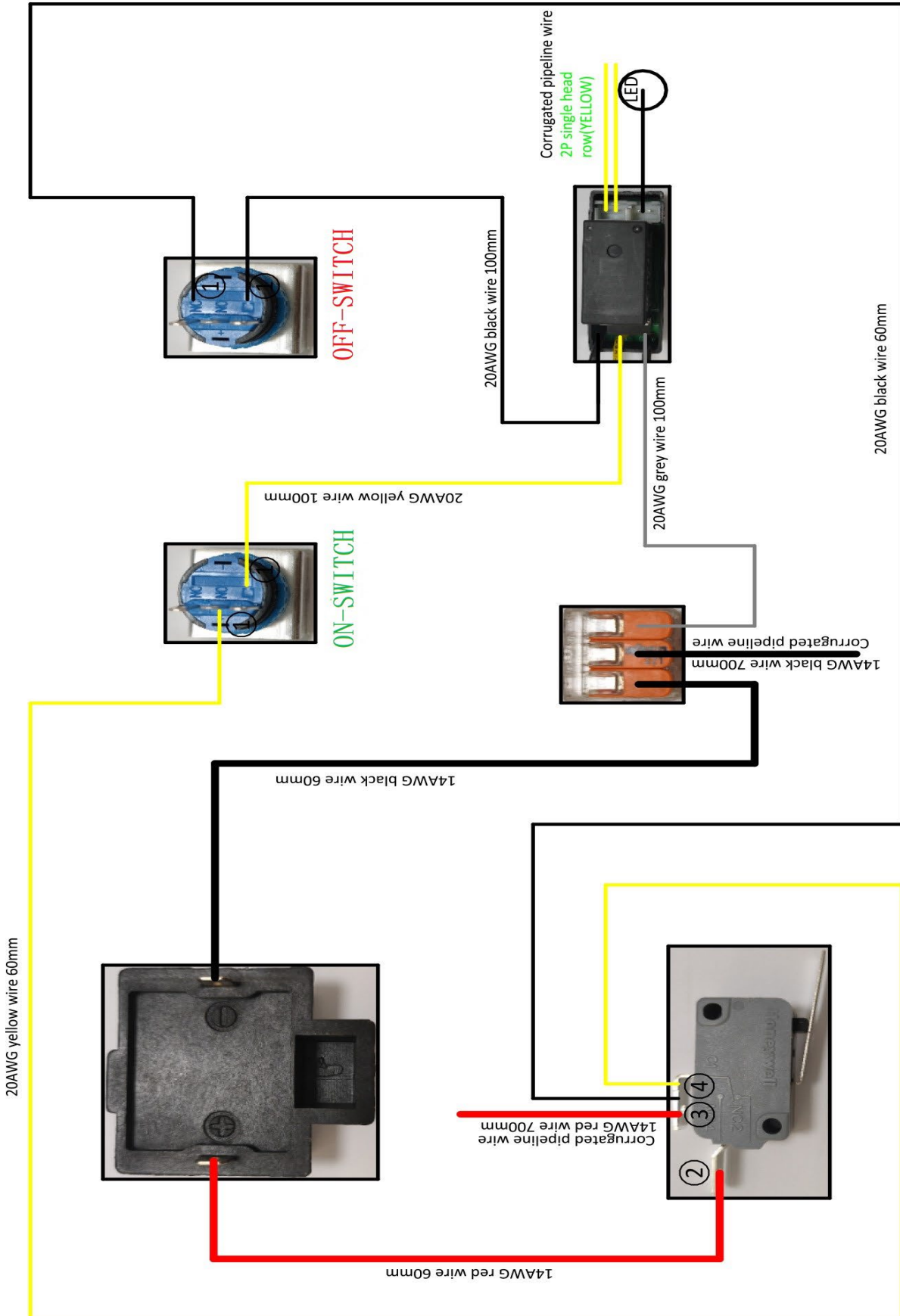

9.4 Warranty and service

Warranty

Holemaker Technology Ltd warrants this magnetic drilling machine to be free of material defects and workmanship errors under normal use for a period of 12 months from the date of purchase.

Serial number:

Date of purchase:

Service

To maximise the lifetime of your HMT machine always use service and parts from an official HMT distribution channel. Whenever in need of such, always contact original point of sales or, if no longer existent, the distributor of HMT products in your country.